

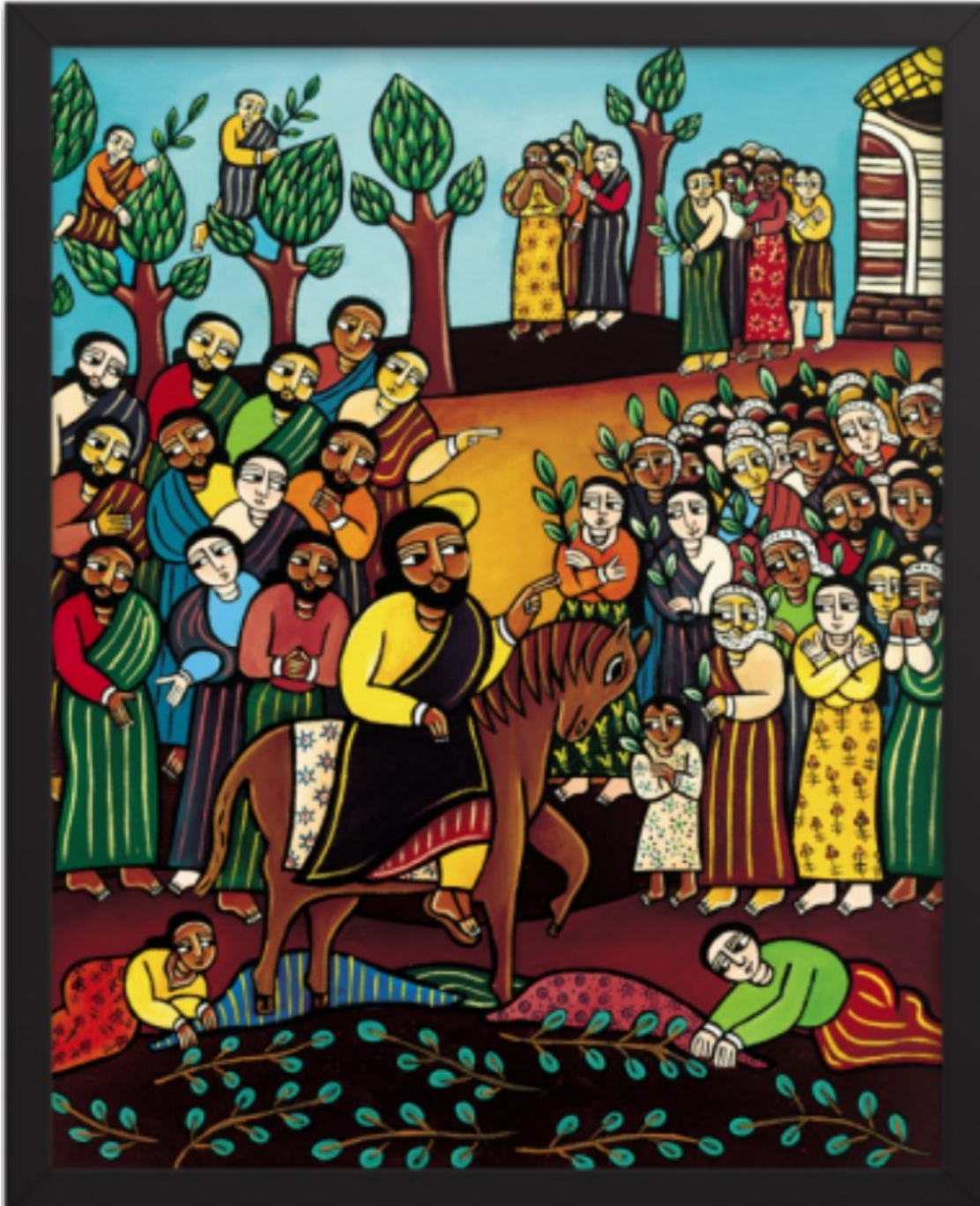

St. Francis' EPISCOPAL CHURCH

Sunday, April 13, 2025

Palm Sunday



ABOUT WORSHIP ON PALM SUNDAY

This is a day of many emotions. We begin our worship outside with the joy of the crowds waving palms, proclaiming Jesus as the unique revelation of God, the Messiah. Our music and readings reflect the joy of the crowds. But during the Eucharistic Prayer, we begin to make a turn toward the Passion of Jesus. We follow communion with silence and the reading of the Passion. We depart in silence.

Colors

We replace the purple and burlap of Lent with red. Red is the color of excitement, energy, power, and all things intense and passionate. As such, red is the color of the Holy Spirit . . . It is used on Palm Sunday and during Holy Week, recalling the work of the Holy Spirit at Jesus' triumphal entry into Jerusalem and His Passion. (Attribution: <https://doers.org/liturgical-colors-of-the-church/>)

Seating

Our chairs are turned to face one another. This is a stark contrast from our usual forward facing chair arrangement. Just as the crowds lining the streets faced one another as Jesus passed and shouted, "Hosanna in the highest!" so, too, do we sing our "hosannas" facing one another.

Baptismal Font

The baptismal bowl is removed and Christ's cross replaces it. This serves as a reminder that "the spiritual grace of our baptism is union with Christ in his death and resurrection" (Book of Common Prayer, Catechism, p. 858). We add palms to the cross today to reflect the dual emotions of the day: beginning in joy and moving toward sorrow.

There are No Mistakes in Worship

At St. Francis' we say, "there are no mistakes in worship." If you sit or stand at a different time than others or sing off key, it is all pleasing to the God we worship. All we do and all we are is brought before God as an offering in our Eucharist.

Bulletin Front Art

This front cover illustrates the story of Palm Sunday through the eyes of artist Laura James. Palm Sunday is the day that marks Jesus' monumental arrival in Jerusalem and the beginning of Holy Week, the last week of the Christian solemn season of Lent that precedes the arrival of Easter. We celebrate Palm Sunday by the blessing and distribution of palm branches, representing the palms that the crowd scattered in front of Christ as he rode into Jerusalem. Jesus' entering the city on a donkey symbolizes arrival in peace rather than as a war-waging king arriving on a horse.

Hosanna is an expression of adoration, praise and joy.

Refrain

Ho - san - na, ho - san - na! Ho -
san - na in the high - est!

Verse response

Cantor Ho - san - na! *All* Ho - san - na!

THE LITURGY OF THE PALMS

Presider Blessed is the Ruler who comes in the name of the Lord:

People **Peace in heaven and glory in the highest.**

Reader Jesus is coming!

People **SHOUT HOSANNA!**

Reader He's riding on a donkey!

People **SHOUT HOSANNA!**

Reader Open the gates!

People **SHOUT HOSANNA!**

Reader Open the ancient doors!

People **SHOUT HOSANNA!**

Reader Don't be afraid!

People **SHOUT HOSANNA!**

Reader Wave the branches!

People **SHOUT HOSANNA!**

Reader Spread out your coats!

People **SHOUT HOSANNA!**

Reader Peace in heaven!

People **SHOUT HOSANNA!**

Reader Glory in highest heaven!

People **SHOUT HOSANNA!**

Refrain

Ho - san - na, ho - san - na! Ho -
san - na in the high - est!

Verse response

Cantor Ho - san - na! *All* Ho - san - na!

Presider Let us pray.

Assist us mercifully with your help, O Lord God of our salvation, that we may enter with joy upon the contemplation of those mighty acts, through which you have given us life and immortality; through Jesus Christ our Lord.

People **Amen.**

THE BLESSING OF THE PALMS

Presider God is with you.

Presider **And also with you.**

Presider Let us give thanks to the Lord our God.

People **It is right to give God thanks and praise.**

Presider It is right to praise you, Almighty God, for the acts of love by which you have redeemed us through Jesus Christ our Lord. On this day he entered the holy city of Jerusalem in triumph, and was proclaimed as King of kings by those who spread their garments and branches of palm along his way.

Please raise palms for blessing.

Let these branches be for us signs of his victory, and grant that we who bear them in his name may ever hail him as our King, and follow him in the way that leads to eternal life; who lives and reigns in glory with you and the Holy Spirit, now and for ever.

People **Amen.**

Presider Blessed is the One who comes in the name of the Lord.

People **SHOUT HOSANNA!**

Deacon Let us go forth in peace.

People **In the name of Christ. Amen.**

HYMN IN PROCESSION

People process to the church as they play instruments, wave branches and sing.

Refrain

Ho - san - na, ho - san - na! Ho -
san - na in the high - est!

Verse response

Cantor Ho - san - na! *All* Ho - san - na!

THE GREETING AND COLLECT

Presider Blessed is the One who comes in the name of our God.

People **Hosanna in the highest!**

Presider God is with you.

People **And also with you.**

Presider Let us pray.

Silence is kept for a time.

Holy and immortal God, as we enter into this holy week turn our hearts to Jerusalem, so that, united with Christ and all the faithful, we may enter the city not made with hands, your promised realm of justice and peace, eternal from age to age.

People **Amen.**

THE LITURGY OF THE WORD *Sit*

THE FIRST LESSON

Reader A reading from the Prophet Isaiah.

50:4-9a

The Lord God has given me
the tongue of a teacher,

that I may know how to sustain
the weary with a word.

Morning by morning he wakens--
wakens my ear
to listen as those who are taught.

The Lord God has opened my ear,
and I was not rebellious,
I did not turn backward.

I gave my back to those who struck me,
and my cheeks to those who pulled out the beard;

I did not hide my face
from insult and spitting.

The Lord God helps me;
therefore I have not been disgraced;

therefore I have set my face like flint,
and I know that I shall not be put to shame;
he who vindicates me is near.

Who will contend with me?
Let us stand up together.

Who are my adversaries?
Let them confront me.

It is the Lord God who helps me;
who will declare me guilty?

The Word of the Lord.

People

Thanks be to God.

THE PSALM OF THE DAY

31

The congregation sings the antiphon one time through before the spoken verses.

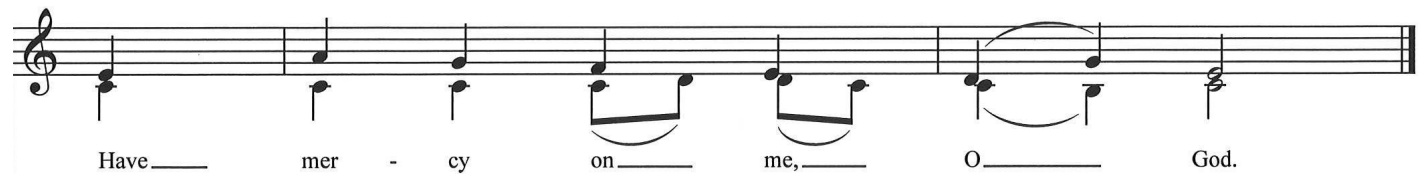

- 9 Have mercy on me, O Lord, for I am in trouble;
my eye is consumed with sorrow,
and also my throat and my belly.
- 10 For my life is wasted with grief,
and my years with sighing;
my strength fails me because of affliction,
and my bones are consumed. **ANTIPHON**
- 11 I have become a reproach to all my enemies and even to my neighbors,
a dismay to those of my acquaintance;
when they see me in the street they avoid me.
- 12 I am forgotten like a dead man, out of mind;
I am as useless as a broken pot. **ANTIPHON**
- 13 For I have heard the whispering of the crowd;
fear is all around;
they put their heads together against me;
they plot to take my life.
- 14 But as for me, I have trusted in you, O Lord.
I have said, "You are my God. **ANTIPHON**
- 15 My times are in your hand;
rescue me from the hand of my enemies,
and from those who persecute me.
- 16 Make your face to shine upon your servant,
and in your loving-kindness save me." **ANTIPHON**

THE SECOND LESSON

Reader

A reading from the letter to the Philippians.

2:5-11

Let the same mind be in you that was in Christ Jesus,
who, though he was in the form of God,
did not regard equality with God
as something to be exploited,

but emptied himself,
taking the form of a slave,
being born in human likeness.

And being found in human form,
he humbled himself
and became obedient to the point of death--
even death on a cross.

Therefore God also highly exalted him
and gave him the name
that is above every name,

so that at the name of Jesus
every knee should bend,
in heaven and on earth and under the earth,

and every tongue should confess
that Jesus Christ is Lord,
to the glory of God the Father.

The Word of the Lord.

People

Thanks be to God.

GOSPEL HYMN *Stand*

THE KING OF GLORY

MHSO 90

Verse 1 and 2 sung before Gospel.



The King of glo - ry comes, the na - tion re - joic - es.



O - pen the gates be - fore him, lift up your voic - es.



1 Who is the King of glo - ry? What shall we call him?
2 In all of Gal - i - lee, in cit - y or vil - lage,
3 He gave his life for us, the pledge of sal - va - tion;



He is Im - man - u - cl, the prom-ised of a - ges.
he goes a - mong his peo - ple, cur - ing their ill - ness.
he took up - on him - self the sin of the na - tions.

THE GOSPEL

Deacon The Holy Gospel of our Lord Jesus Christ according to Luke. 19:28-40

People **Glory to you, Lord Christ.**

After telling a parable to the crowd at Jericho, Jesus went on ahead, going up to Jerusalem. When he had come near Bethphage and Bethany, at the place called the Mount of Olives, he sent two of the disciples, saying, "Go into the village ahead of you, and as you enter it you will find tied there a colt that has never been ridden. Untie it and bring it here. If anyone asks you, 'Why are you untying it?' just say this, 'The Lord needs it.'" So those who were sent departed and found it as he had told them. As they were untying the colt, its owners asked them, "Why are you untying the colt?" They said, "The Lord needs it." Then they brought it to Jesus; and after throwing their cloaks on the colt, they set Jesus on it. As he rode along, people kept spreading their cloaks on the road. As he was now approaching the path down from the Mount of Olives, the whole multitude of the disciples began to praise God joyfully with a loud voice for all the deeds of power that they had seen, saying,

The congregation says:

**"Blessed is the king
who comes in the name of the Lord!**

**Peace in heaven,
and glory in the highest heaven!"**

Deacon Some of the Pharisees in the crowd said to him, "Teacher, order your disciples to stop." He answered, "I tell you, if these were silent, the stones would shout out."

The Gospel of the Lord.

People **Praise to you, Lord Christ.**

GOSPEL HYMN *Stand*

THE KING OF GLORY

MHSO 90

Verse 3 sung after Gospel reading. Music on previous page.

SERMON *Sit*

THE REV. LAURIE ANZILOTTI

PRAYERS OF THE PEOPLE *Stand*

Cantor begins the Prayers of the People by singing the response one time through.



O God, hear us; hear our prayer.—

Intercessor Let us pray for the Church and for the world. Grant, Almighty God, that all who confess your Name may be united in your truth, live together in your love, and reveal your glory in the world.

People **O God, hear us; hear our prayer.**

Intercessor Guide the people of this land, and of all the nations, in the ways of justice and peace; that we may honor one another and serve the common good.

People **O God, hear us; hear our prayer.**

Intercessor Give us all the reverence for the earth as your own creation, that we may use its resources rightly in the service of others and to your honor and glory.

People **O God, hear us; hear our prayer.**

Intercessor Bless all whose lives are closely linked with ours, and grant that we may serve Christ in them, and love one another as he loves us.

People **O God, hear us; hear our prayer.**

Intercessor Comfort and heal all those who suffer in body, mind, and spirit, especially those on our prayer list: Noel Choweller, Bob Carter, Wayne & Bev Hoover, Ann Widner, Sylvia Ahmad, Chuck Dougherty, Troy McCart, John Doolittle, Ernie Benecke, Doris Schaefer, Barb Sacco, Anna Mackey, June Goodson, Karl Stroud, Chris Boswell, Violet Tenholder, Bethany Frost, Mick Kreisel, Tim Booker, Tom Schlotter, and Joe O'Reilly.

People **O God, hear us; hear our prayer.**

Intercessor We commend to your mercy all who have died. Give to them eternal rest and peace. May we, following the examples of Francis and Clare and all the saints, come to the joy of your eternal kingdom.

People **O God, hear us; hear our prayer.**

Presider Lord, hear the prayers of your family and fulfill our desires and petitions as may be best for us through your child Jesus Christ.

People Amen.

Please see our parish Prayer Lists, which can be found on the bulletin, for biddings and concerns. If you would like to make a prayer request, please complete our Prayer Request Form which can be accessed at StFrancisEureka.com or on paper at the back of the church.

THE PEACE

Presider The peace of the Lord be always with you.

People And also with you.

We invite you to extend the peace of God to those in the congregation.

ANNOUNCEMENTS AND WELCOME Sit

OFFERTORY ANTHEM

ALL GLORY, LAUD AND HONOR

H 154

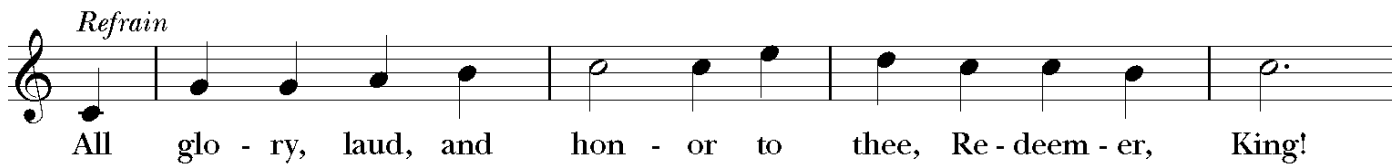

At 10:30am, as the ushers bring forth the offering, all stand.

EUCHARIST

Presider The Lord be with you.

People **And also with you.**

Presider Lift up your hearts.

People **We lift them to the Lord.**

Presider Let us give thanks to the Lord our God.

People **It is right to give God thanks and praise.**

Presider It is truly right, and good and joyful, to give you thanks all-holy God, source of life and fountain of mercy.

You bid your faithful people cleanse their hearts, and prepare with joy for the Paschal feast; that, fervent in prayer and in works of mercy, and renewed by your Word and Sacraments, they may come to the fullness of grace which you have prepared for those who love you.

Therefore, joining with Angels and Archangels and with the faithful of every generation, we lift our voices with all creation as we say/sing:

Say at 8am: **Holy, holy, holy Lord, God of power and might, heaven and earth are full of your glory.**

Hosanna in the highest.

Blessed is the one who comes in the name of the Lord.

Hosanna in the highest.

Sing at 10:30am:

Ho-ly, ho-ly, ho - ly Lord,
God of pow-er, God of might, heav - en and
earth are full of your glo - ry. Ho -
san - na in the high - est. Bless - ed the
one who comes in the name of the Lord.
Ho - san - na in the high - est, ho -
san - na in the high - est.

Presider

Blessed are you, gracious God, creator of the universe and giver of life. You formed us in your own image and called us to dwell in your infinite love. You gave the world into our care that we might be your faithful stewards and show forth your bountiful grace.

But we failed to honor your image in one another and in ourselves; we would not see your goodness in the world around us; and so we violated your creation, abused one another, and rejected your love. Yet you never ceased to care for us, and prepared the way of salvation for all people.

Through Abraham and Sarah you called us into covenant with you. You delivered us from slavery, sustained us in the wilderness, and raised up prophets to renew your promise of salvation. Then, in the fullness of time, you sent your eternal Word, made mortal flesh in Jesus. Born into the human family, and dwelling among us, he revealed your glory. Giving himself freely to death on the cross, he triumphed over evil, opening the way of freedom and life.

On the night before he died for us, our Savior Jesus Christ took bread, and when he had given thanks to you, he broke it, and gave it to his friends, and said: "Take, eat: This is my Body which is given for you. Do this for the remembrance of me."

As supper was ending, Jesus took the cup of wine, and when he had given thanks, he gave

it to them, and said: "Drink this, all of you: This is my Blood of the new Covenant, which is poured out for you and for all for the forgiveness of sins.

Whenever you drink it, do this for the remembrance of me."

Presider and People

Priest:



Let us pro-claim the mys - ter - y of faith:

All



Christ has died, Christ is ris-en, Christ will come a - gain.



Christ has died, Christ is ris-en, Christ will come a - gain!

Presider Remembering his death and resurrection, we now present to you from your creation this bread and this wine. By your Holy Spirit may they be for us the Body and Blood of our Savior Jesus Christ.

Grant that we who share these gifts may be filled with the Holy Spirit and live as Christ's Body in the world.

Bring us into the everlasting heritage of your daughters and sons, that with the Blessed Mary, St. Francis, St. Clare, and all your saints, past, present, and yet to come, we may praise your Name for ever.

Through Christ and with Christ and in Christ, in the unity of the Holy Spirit, to you be honor, glory, and praise, for ever and ever.

All **Amen.**

THE LORD'S PRAYER

Presider And now, as our Savior Christ has taught us, we are bold to say,

People **Our Father, who art in heaven,
hallowed be thy Name,
thy kingdom come,
thy will be done,
on earth as it is in heaven.
Give us this day our daily bread.
And forgive us our trespasses,
as we forgive those
who trespass against us.
And lead us not into temptation,
but deliver us from evil.
For thine is the kingdom,
and the power, and the glory,
for ever and ever. Amen.**

THE BREAKING OF THE BREAD

The Presider breaks the consecrated Bread. A period of silence is kept.

Presider Christ our Passover is sacrificed for us.

People **Therefore let us keep the feast.**

FRACTION ANTHEM

At 8am, spoken.

All **O Lamb of God, that takes away the sins of the world, have mercy upon us.**

O Lamb of God, that takes away the sins of the world, have mercy upon us.

O Lamb of God, that takes away the sins of the world, grant us peace.

At 10:30am, sung.

Cantor: Je - sus, Lamb of God, **All** you take a-way the sins of the world:
have mer - cy, have mer - cy on us.

Can- 1. Bread of life and sav - ing cup,
2. King of kings and Lord of lords, you take a - way the
3. Lov - ing Sav - ior, Prince of peace,
All sins of the world: have mer-cy, have mer-cy on us.

Can- Je - sus, Lamb of God, **All** you take a-way the sins of the world:
have mer - cy, and grant us your peace.

Presider The Gifts of God for the People of God.

Our bread is gluten-, dairy- and nut-friendly. This Eucharistic table does not belong to the Episcopal Church or to St. Francis'. This is God's table, and all are welcome. In the Episcopal Church, we receive both the bread and wine, the Body and Blood of Jesus. If you choose not to receive communion, please come forward and cross your arms over your heart to receive a blessing.

10:30 am only



1 O sa - cred head, sore wound - ed, de - filed and put to scorn;
 2 Thy beau - ty, long - de - sir - ed, hath va - nished from our sight;
 3 In thy most bit - ter pas - sion my heart to share doth cry,
 *4 What lan - guage shall I bor - row to thank thee, dear - est friend,
 *5 My days are few, O fail not, with thine im - mor - tal power,

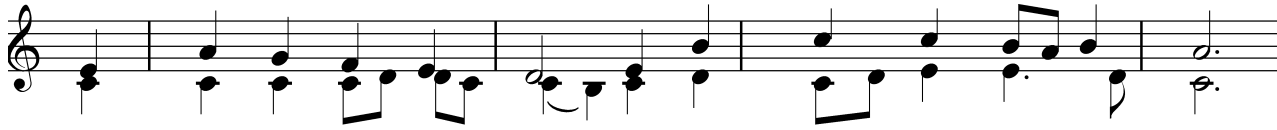

1 O king - ly head, sur - round - ed with mock - ing crown of thorn:
 2 thy power is all ex - pir - ed, and quenched the light of light.
 3 with thee for my sal - va - tion up - on the cross to die.
 4 for this thy dy - ing sor - row, thy pi - ty with - out end?
 5 to hold me that I quail not in death's most fear - ful hour;

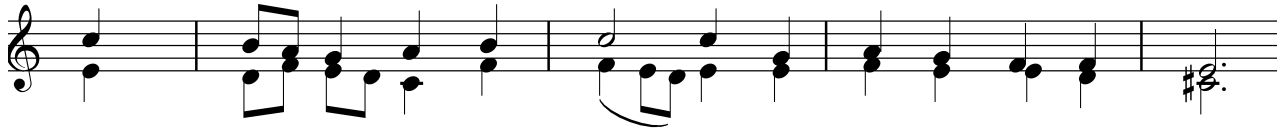

1 what sor - row mars thy gran - deur? Can death thy bloom de - flower?
 2 Ah me! for whom thou di - est, hide not so far thy grace:
 3 Ah, keep my heart thus mov - ed to stand thy cross be - neath,
 4 Oh, make me thine for - ev - er! and should I faint - ing be,
 5 that I may fight be - friend - ed, and see in my last strife



1 O coun - te - nance whose splen - dor the hosts of heaven a - dore!
 2 show me, O Love most high - est, the bright - ness of thy face.
 3 to mourn thee, well - be - lov - ed, yet thank thee for thy death.
 4 Lord, let me nev - er, nev - er, out - live my love for thee.
 5 to me thine arms ex - tend - ed up - on the cross of life.

THE GREAT SILENCE

Once all have received communion and the Holy Table has been cleared the community observes a moment of silent reflection and prayer. (The silence begins and ends with the sound of a bell.)

POST-COMMUNION PRAYER *Stand*

Presider God is with you.

People **And also with you.**

Presider Let us pray.

Lord Jesus Christ, you humbled yourself in taking the form of a servant, and in obedience died on the cross for our salvation: give us the mind to follow you and to proclaim you as Sovereign, to the glory of God.

People **Faithful God, may we who share this banquet glory in the cross of our Lord Jesus Christ, our salvation, life and hope, who reigns now and for ever. Amen.**

THE PASSION *Sit*

Lector The Passion of our Lord Jesus Christ according to Luke. 22:14-23:56

When the hour for the Passover meal came, Jesus took his place at the table, and the apostles with him. He said to them, "I have eagerly desired to eat this Passover with you before I suffer; for I tell you, I will not eat it until it is fulfilled in the kingdom of God." Then he took a cup, and after giving thanks he said, "Take this and divide it among yourselves; for I tell you that from now on I will not drink of the fruit of the vine until the kingdom of God comes." Then he took a loaf of bread, and when he had given thanks, he broke it and gave it to them, saying, "This is my body, which is given for you. Do this in remembrance of me." And he did the same with the cup after supper, saying, "This cup that is poured out for you is the new covenant in my blood. But see, the one who betrays me is with me, and his hand is on the table. For the Son of Man is going as it has been determined, but woe to that one by whom he is betrayed!" Then they began to ask one another, which one of them it could be who would do this.

A dispute also arose among them as to which one of them was to be regarded as the greatest. But he said to them, "The kings of the Gentiles lord it over them; and those in authority over them are called benefactors. But not so with you; rather the greatest among you must become like the youngest, and the leader like one who serves. For who is greater, the one who is at the table or the one who serves? Is it not the one at the table? But I am among you as one who serves.

"You are those who have stood by me in my trials; and I confer on you, just as my Father has conferred on me, a kingdom, so that you may eat and drink at my table in my kingdom, and you will sit on thrones judging the twelve tribes of Israel.

"Simon, Simon, listen! Satan has demanded to sift all of you like wheat, but I have prayed for you that your own faith may not fail; and you, when once you have turned back, strengthen your brothers." And he said to him, "Lord, I am ready to go with you to prison and to death!" Jesus said, "I tell you, Peter, the cock will not crow this day, until you have

denied three times that you know me."

He said to them, "When I sent you out without a purse, bag, or sandals, did you lack anything?" They said, "No, not a thing." He said to them, "But now, the one who has a purse must take it, and likewise a bag. And the one who has no sword must sell his cloak and buy one. For I tell you, this scripture must be fulfilled in me, 'And he was counted among the lawless'; and indeed what is written about me is being fulfilled." They said, "Lord, look, here are two swords." He replied, "It is enough."

He came out and went, as was his custom, to the Mount of Olives; and the disciples followed him. When he reached the place, he said to them, "Pray that you may not come into the time of trial." Then he withdrew from them about a stone's throw, knelt down, and prayed, "Father, if you are willing, remove this cup from me; yet, not my will but yours be done." Then an angel from heaven appeared to him and gave him strength. In his anguish he prayed more earnestly, and his sweat became like great drops of blood falling down on the ground. When he got up from prayer, he came to the disciples and found them sleeping because of grief, and he said to them, "Why are you sleeping? Get up and pray that you may not come into the time of trial."

While he was still speaking, suddenly a crowd came, and the one called Judas, one of the twelve, was leading them. He approached Jesus to kiss him; but Jesus said to him, "Judas, is it with a kiss that you are betraying the Son of Man?" When those who were around him saw what was coming, they asked, "Lord, should we strike with the sword?" Then one of them struck the slave of the high priest and cut off his right ear. But Jesus said, "No more of this!" And he touched his ear and healed him. Then Jesus said to the chief priests, the officers of the temple police, and the elders who had come for him, "Have you come out with swords and clubs as if I were a bandit? When I was with you day after day in the temple, you did not lay hands on me. But this is your hour, and the power of darkness!"

Then they seized him and led him away, bringing him into the high priest's house. But Peter was following at a distance. When they had kindled a fire in the middle of the courtyard and sat down together, Peter sat among them. Then a servant-girl, seeing him in the firelight, stared at him and said, "This man also was with him." But he denied it, saying, "Woman, I do not know him." A little later someone else, on seeing him, said, "You also are one of them." But Peter said, "Man, I am not!" Then about an hour later still another kept insisting, "Surely this man also was with him; for he is a Galilean." But Peter said, "Man, I do not know what you are talking about!" At that moment, while he was still speaking, the cock crowed. The Lord turned and looked at Peter. Then Peter remembered the word of the Lord, how he had said to him, "Before the cock crows today, you will deny me three times." And he went out and wept bitterly.

Now the men who were holding Jesus began to mock him and beat him; they also blindfolded him and kept asking him, "Prophecy! Who is it that struck you?" They kept heaping many other insults on him.

When day came, the assembly of the elders of the people, both chief priests and scribes,

gathered together, and they brought him to their council. They said, "If you are the Messiah, tell us." He replied, "If I tell you, you will not believe; and if I question you, you will not answer. But from now on the Son of Man will be seated at the right hand of the power of God." All of them asked, "Are you, then, the Son of God?" He said to them, "You say that I am." Then they said, "What further testimony do we need? We have heard it ourselves from his own lips!"

Then the assembly rose as a body and brought Jesus before Pilate. They began to accuse him, saying, "We found this man perverting our nation, forbidding us to pay taxes to the emperor, and saying that he himself is the Messiah, a king." Then Pilate asked him, "Are you the king of the Jews?" He answered, "You say so." Then Pilate said to the chief priests and the crowds, "I find no basis for an accusation against this man." But they were insistent and said, "He stirs up the people by teaching throughout all Judea, from Galilee where he began even to this place."

When Pilate heard this, he asked whether the man was a Galilean. And when he learned that he was under Herod's jurisdiction, he sent him off to Herod, who was himself in Jerusalem at that time. When Herod saw Jesus, he was very glad, for he had been wanting to see him for a long time, because he had heard about him and was hoping to see him perform some sign. He questioned him at some length, but Jesus gave him no answer. The chief priests and the scribes stood by, vehemently accusing him. Even Herod with his soldiers treated him with contempt and mocked him; then he put an elegant robe on him, and sent him back to Pilate. That same day Herod and Pilate became friends with each other; before this they had been enemies.

Pilate then called together the chief priests, the leaders, and the people, and said to them, "You brought me this man as one who was perverting the people; and here I have examined him in your presence and have not found this man guilty of any of your charges against him. Neither has Herod, for he sent him back to us. Indeed, he has done nothing to deserve death. I will therefore have him flogged and release him."

Then they all shouted out together, "Away with this fellow! Release Barabbas for us!" (This was a man who had been put in prison for an insurrection that had taken place in the city, and for murder.) Pilate, wanting to release Jesus, addressed them again; but they kept shouting, "Crucify, crucify him!" A third time he said to them, "Why, what evil has he done? I have found in him no ground for the sentence of death; I will therefore have him flogged and then release him." But they kept urgently demanding with loud shouts that he should be crucified; and their voices prevailed. So Pilate gave his verdict that their demand should be granted. He released the man they asked for, the one who had been put in prison for insurrection and murder, and he handed Jesus over as they wished.

As they led him away, they seized a man, Simon of Cyrene, who was coming from the country, and they laid the cross on him, and made him carry it behind Jesus. A great number of the people followed him, and among them were women who were beating their breasts and wailing for him. But Jesus turned to them and said, "Daughters of Jerusalem, do not weep for me, but weep for yourselves and for your children. For the

days are surely coming when they will say, 'Blessed are the barren, and the wombs that never bore, and the breasts that never nursed.' Then they will begin to say to the mountains, 'Fall on us'; and to the hills, 'Cover us.' For if they do this when the wood is green, what will happen when it is dry?"

Two others also, who were criminals, were led away to be put to death with him. When they came to the place that is called The Skull, they crucified Jesus there with the criminals, one on his right and one on his left. Then Jesus said, "Father, forgive them; for they do not know what they are doing." And they cast lots to divide his clothing. And the people stood by, watching; but the leaders scoffed at him, saying, "He saved others; let him save himself if he is the Messiah of God, his chosen one!" The soldiers also mocked him, coming up and offering him sour wine, and saying, "If you are the King of the Jews, save yourself!" There was also an inscription over him, "This is the King of the Jews."

One of the criminals who were hanged there kept deriding him and saying, "Are you not the Messiah? Save yourself and us!" But the other rebuked him, saying, "Do you not fear God, since you are under the same sentence of condemnation? And we indeed have been condemned justly, for we are getting what we deserve for our deeds, but this man has done nothing wrong." Then he said, "Jesus, remember me when you come into your kingdom." He replied, "Truly I tell you, today you will be with me in Paradise."

It was now about noon, and darkness came over the whole land until three in the afternoon, while the sun's light failed; and the curtain of the temple was torn in two. Then Jesus, crying with a loud voice, said, "Father, into your hands I commend my spirit." Having said this, he breathed his last. [BOTH CLERGY KNEEL IN PRAYER]

When the centurion saw what had taken place, he praised God and said, "Certainly this man was innocent." And when all the crowds who had gathered there for this spectacle saw what had taken place, they returned home, beating their breasts. But all his acquaintances, including the women who had followed him from Galilee, stood at a distance, watching these things.

Now there was a good and righteous man named Joseph, who, though a member of the council, had not agreed to their plan and action. He came from the Jewish town of Arimathea, and he was waiting expectantly for the kingdom of God. This man went to Pilate and asked for the body of Jesus. Then he took it down, wrapped it in a linen cloth, and laid it in a rock-hewn tomb where no one had ever been laid. It was the day of Preparation, and the sabbath was beginning. The women who had come with him from Galilee followed, and they saw the tomb and how his body was laid. Then they returned, and prepared spices and ointments.

On the sabbath they rested according to the commandment.

Our Palm Sunday service ends in silence. There is no blessing, sending hymn, or dismissal because our liturgy continues on throughout this Holy Week. Join in prayer with the St. Francis' community every day this week. See the Holy Week schedule on the back page.

Palm Leaf Cross Directions

Supplies: One palm leaf strip about 24-26" in length, 1/2" in width, tapering to the end.

STEP: 1

Fold the palm leaf down,
about 5-6" from the bottom.



STEP: 2

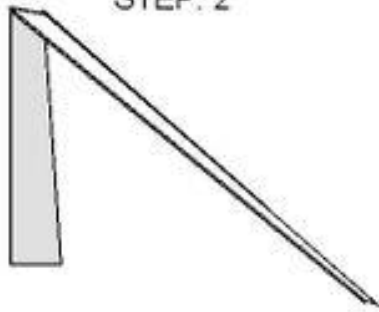

STEP: 3



STEP: 4

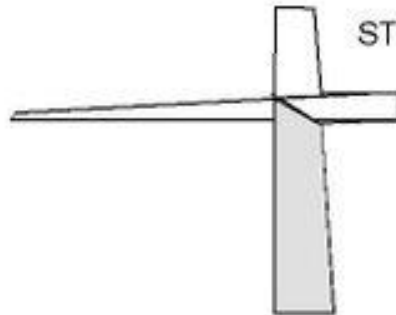

STEP: 5

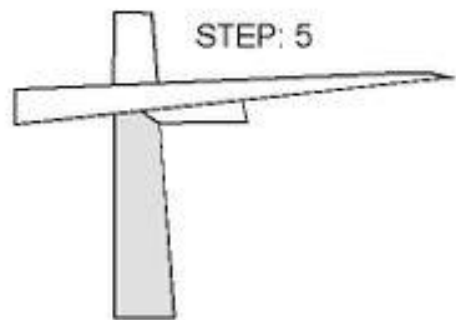

STEP: 6

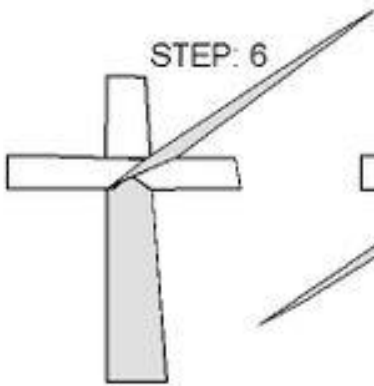

STEP: 7

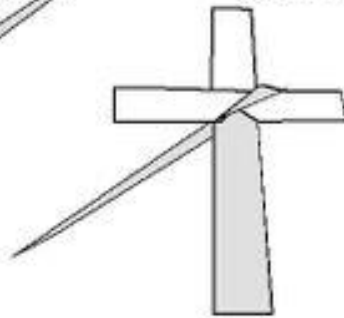

STEP: 8

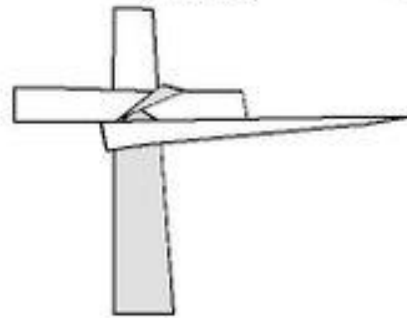

STEP: 9

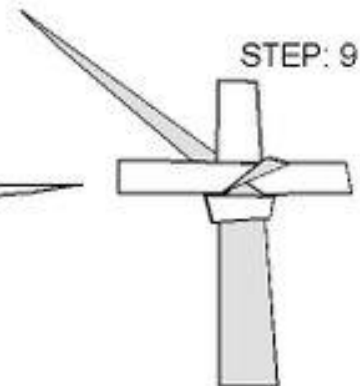

STEP: 10

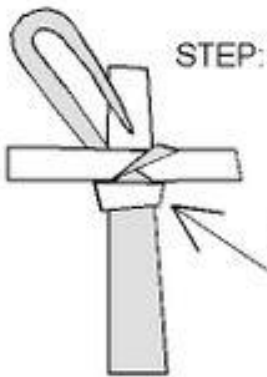

Tuck in the
tapered end of
the palm leaf
and pull it
through.

STEP: 11



STEP: 12

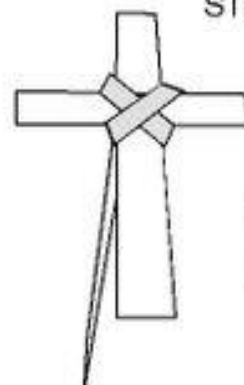

Turn the
cross over.
This is the
front view.

HOLY WEEK AND EASTER SCHEDULE

MONDAY, APRIL 14, TUESDAY, APRIL 15, AND WEDNESDAY, APRIL 16

Evening Prayer at 5:30pm

This Evening Prayer is designed to reflect on the day, express gratitude, and prepare for rest. It is a time of quiet reflection, featuring instrumental flute and piano. Reception with food and drink to follow each evening.

MAUNDY THURSDAY, APRIL 17

Community Meal at 6pm. Share a meal with friends as Jesus did. Meal provided by Dave and Denise Denner.

Worship at 7pm in person and on YouTube.

Service commemorating the new "mandatum" or commandment to "love one another as I have loved you." (John 13:34)

GOOD FRIDAY, APRIL 18

Worship at noon in person or on YouTube; worship at 7pm in person

Commemoration of the crucifixion of Jesus with veneration of the cross

EASTER VIGIL, SATURDAY, APRIL 19

Worship at 7:45pm in person

Easter Vigil is a liturgy that begins in darkness and is considered the first celebration of Easter. In it, the congregation lights the Paschal (Easter) candle, hears the salvation story, renews baptismal vows and celebrates the first Eucharist of Easter. Easter Vigil is the heart of our Christian life.

EASTER SUNDAY, APRIL 20

10:30am Worship in person and on YouTube

11:30am Easter Egg Hunt and Potluck Brunch